

# **TWO-POST LIFTS**

**SPOA3T - HYDRAULIC**



# SPOA3T

THE NEW SPOA3T 2-POST LIFTS OFFER MAXIMUM DRIVE-THROUGH CLEARANCE WITH MINIMUM EXTERNAL DIMENSIONS. THE ASYMMETRICAL DESIGN OF THE POSTS AND SUPPORTING ARMS ALSO PROVIDES A SPACIOUS PICK-UP AREA – THE LIFT CAN BE ENTERED FROM EITHER SIDE.

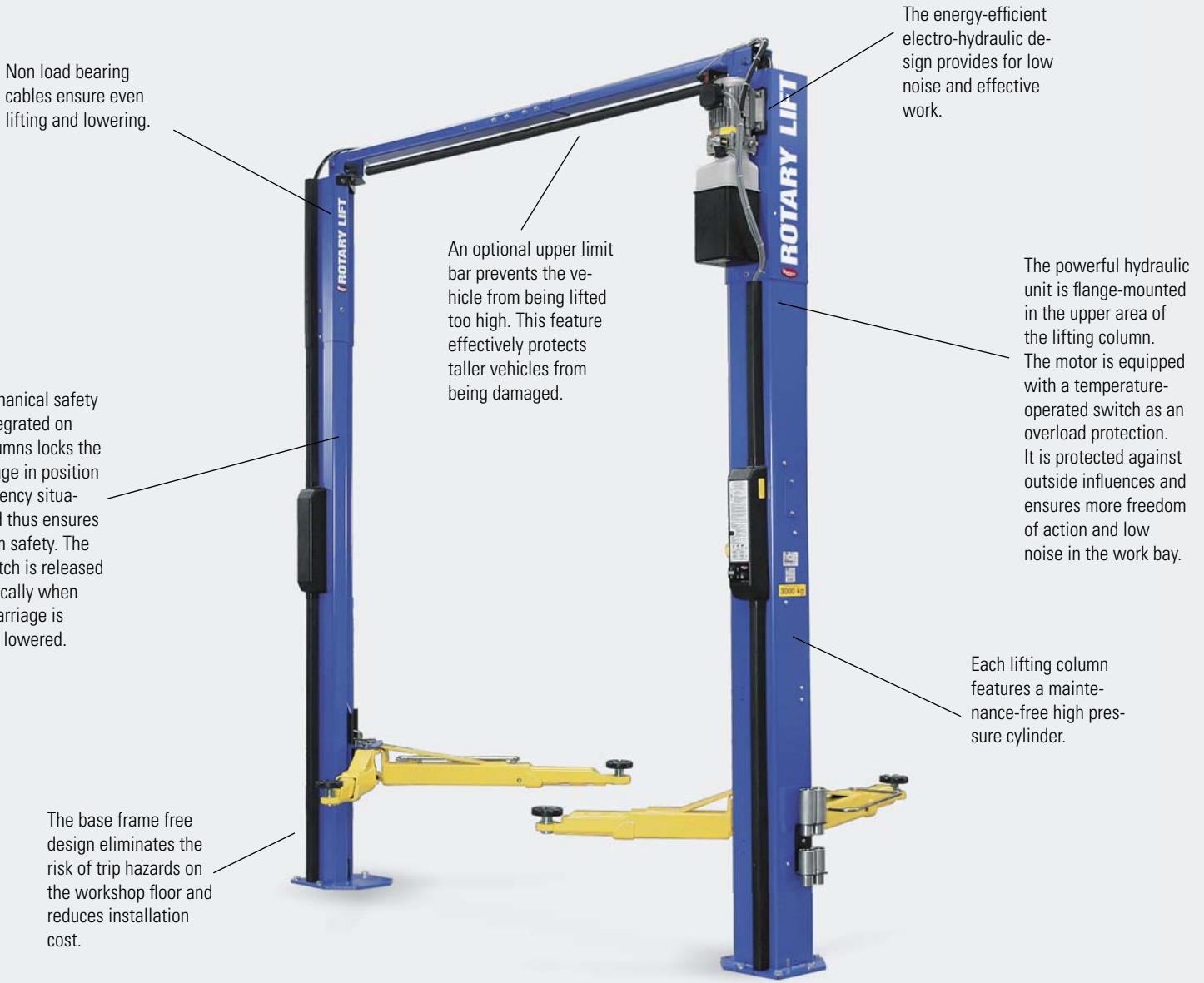

Non load bearing cables ensure even lifting and lowering.

The energy-efficient electro-hydraulic design provides for low noise and effective work.

An optional upper limit bar prevents the vehicle from being lifted too high. This feature effectively protects taller vehicles from being damaged.

The powerful hydraulic unit is flange-mounted in the upper area of the lifting column. The motor is equipped with a temperature-operated switch as an overload protection. It is protected against outside influences and ensures more freedom of action and low noise in the work bay.

The mechanical safety latch integrated on both columns locks the lift carriage in position in emergency situations and thus ensures maximum safety. The safety latch is released automatically when the lift carriage is raised or lowered.

Each lifting column features a maintenance-free high pressure cylinder.

The base frame free design eliminates the risk of trip hazards on the workshop floor and reduces installation cost.

The figure shows SPOA3T with optional accessories.

## DETAILS

The rear supporting arms can swivel through 180°. This substantially increases the pick-up flexibility, allowing vehicles with a short or long wheelbase to be lifted without difficulty.

The lift carriage bearings are made of self-lubricating and absolutely maintenance-free Tivar® 1000 polyethylene. Two characteristics that help reduce operating expenses considerably.

The supporting arms are automatically locked in position during the lifting operation. Once the lift has been completely lowered, this interlock is automatically released. The very narrow spacing between the locking positions and a manual unlocking function enhance the ease of use.

The modern, asymmetrical post design provides a generous drive-through clearance of 2,350 mm, so even large vehicles can be easily accommodated.

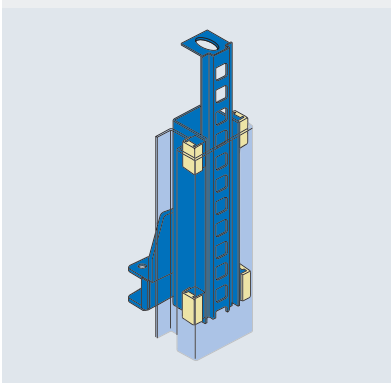

Model:	SPOA3T	SPOA3T
	2-stage sup. arms	3-stage sup. arms
Capacity	3000 kg	3000 kg
A. Stroke	1978 mm	1945 mm
Overall height	3560 mm	3560 mm
B. EH1	3865 mm	3865 mm
EH2	4170 mm	4170 mm
C. Overall width	3000 mm	3000 mm
D. Drive through clearance	2350 mm	2350 mm
Switchoff level (optional)	3455 mm	3455 mm
E. EH1	3760 mm	3760 mm
EH2	4065 mm	4065 mm
F. Support bracket length on the front min.	594 mm	550 mm
G. Support bracket length on the front max.	853 mm	1100 mm
H. Support bracket length on the rear min.	851 mm	875 mm
I. Support bracket length on the rear max.	1394 mm	1475 mm
J. Rotary plate height min.	106 mm	89 mm
K. Rotary plate height max.	174 mm	145 mm
M. Column spacing, interior dimension	2580 mm	2580 mm
N. Cylinder height at max. stroke*	3785 mm	3785 mm
Motor performance	3,4 kW	3,4 kW
Electrical connection	230/400 V, (3 phases)	230/400 V, 50 Hz
Lifting time	31 sec.	31 sec.
Required ceiling height	3800 mm	3800 mm
EH1	3920 mm	3920 mm
EH2	4230 mm	4230 mm

\* Cylinder height with standard models larger than overall height.

Other models, e.g. for vehicles with long wheelbases, motorhomes etc. on request.

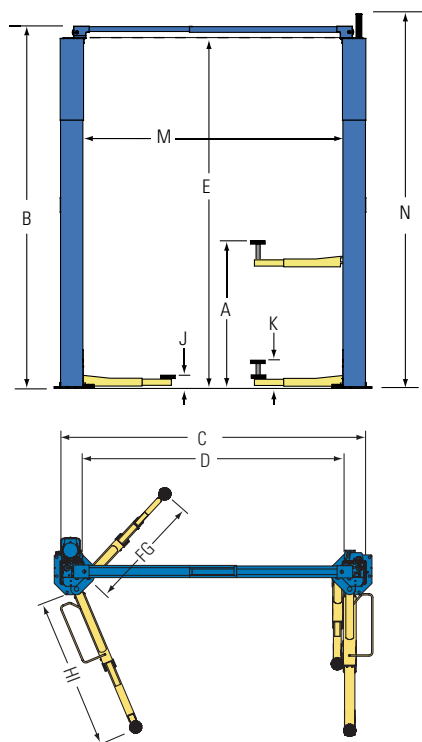

The asymmetrical construction combined with the design of the supporting arms provides good door clearance – either in front of or behind the lifting post.



## ACCESSORIES

Rotary adaptor extension kit for passenger cars  
(4 x 89 mm, 4 x 127 mm)



Rotary adaptor extension kit for delivery trucks/vans (4 x 200 mm)



Support kit for delivery trucks/vans  
(4 x U-support)



Special rotary plate for vehicles with a low degree of ground clearance and pick up points with restricted surfaces.



3-stage supporting arms



Tool storage trays, magnetic





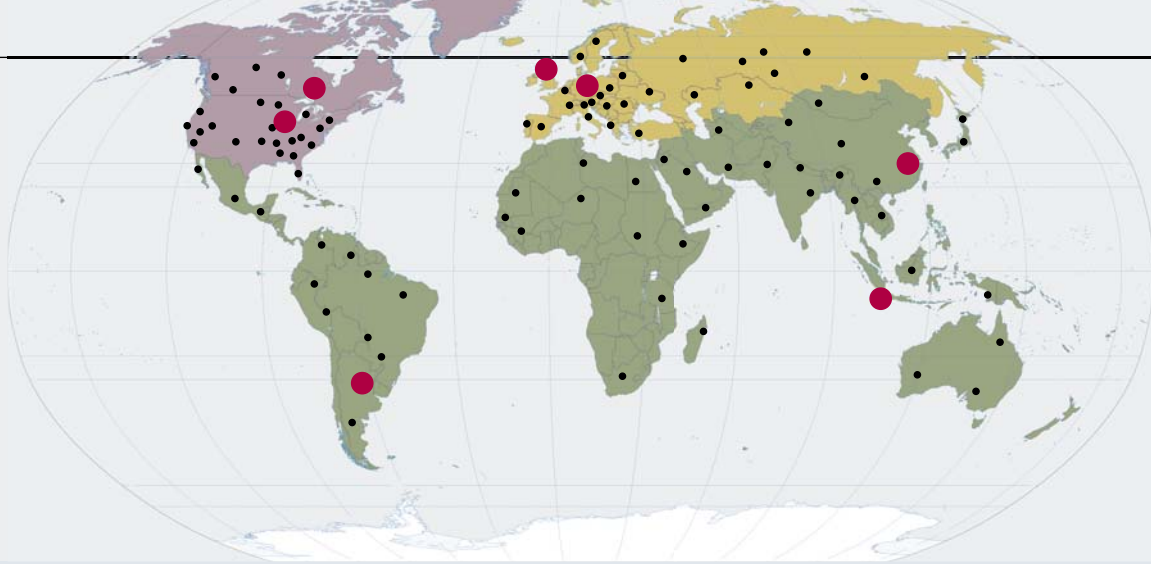

## LOOK LOCAL - ACT GLOBAL

WE ACT WITH FOCUS ON OUR CUSTOMERS AND THEIR REQUIREMENTS. LOCAL SUBSIDIARIES WORLDWIDE PERMIT US TO DO SO, AND AT THE SAME TIME, OFFER A HIGH DEGREE OF PRODUCT FLEXIBILITY.

Rotary Lift's story of success started in 1924. Inspired by a barber chair rising in the air, company founder Peter Lunati developed the world's first vehicle lift. The lift could rotate. This design made it possible for vehicles to drive on and off the lift in forward gear. An important argument considering the frequent problem of reversing at that time. The patent for the lift was granted on September 1, 1925 and Rotary Lift – the company – was born.

Over 75 years later, Rotary Lift has grown to become the world leader in vehicle lift productivity. Apart from the headquarters in Madison, Indiana (USA) and the European Control Center in Bräunlingen, Germany, numerous global subsidiaries attend to the desires and requirements of our customers.

With this unique network, Rotary Lift has the opportunity of analyzing and recognizing market trends at an early stage and of applying that knowledge to generate global standards. Worldwide product releases of numerous vehicle manufacturers emphasize this approach.



**Headquarter**  
Madison, IN USA

**European Control Center**  
Bräunlingen, Germany

**Rotatable**  
One of the first lifts of Rotary Lift



BlitzRotary GmbH  
Hüfanger Straße 55  
D-78199 Bräunlingen  
A **DOVER** COMPANY

Telefon +49.771.9233.0  
Telefax +49.771.9233.99  
europe@rotarylif.com  
www.rotarylif.com

USA: +1.812.273.1622 (Headquarter)  
Canada: +1.905.812.9920  
United Kingdom: +44.178.747.7711  
AustralAsia: +60.3.7660.0285

