

Vehicle Lifts

B440 MoT Class 4

4 tonne, 4.3M platforms

B450 MoT Class 7

5 tonne, 5.2M platforms

Developed over 25 years of vehicle lift manufacturing, the Boston B440 and B450 are fine examples of leading 4 poster technology. Robust, attractive and designed to meet the demands of future MoT legislation. Both models have platform recesses into which our PD-301 or PD-302 play detectors can be fitted or retrofitted at anytime.

Boston 4 post lifts provide airline outlets fitted to the lift pillar and also between platforms for convenient use of air tools and jacking beams. We also provide a 12v socket for inspection lamps. Platform lengths exceed MoT regulations to suit the latest range of long wheelbase vehicles.

These are some of the features which combine to produce probably the best lifts in the UK.

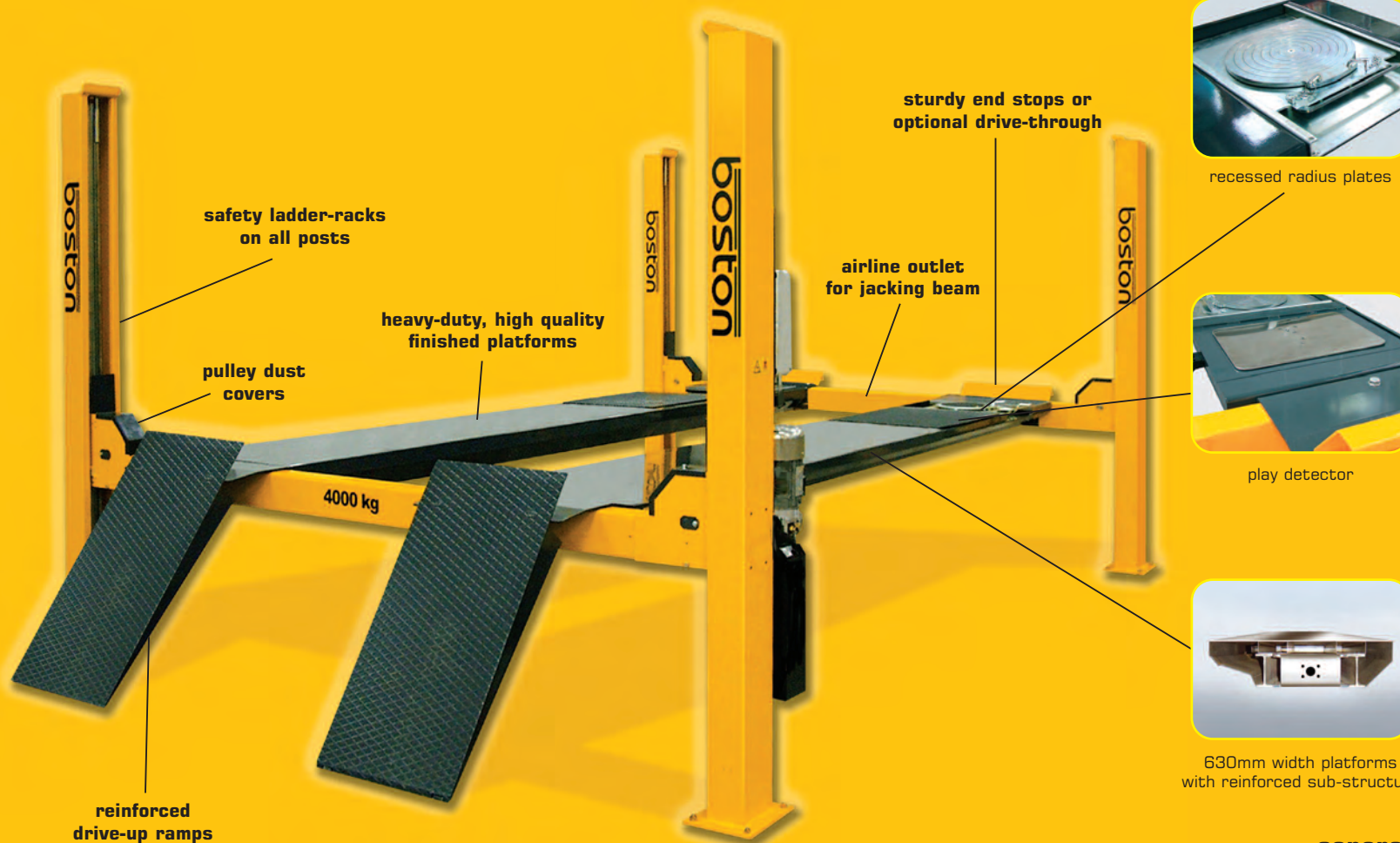

recessed radius plates



play detector



630mm width platforms with reinforced sub-structure

B440 Class 4 / B450 Class 7

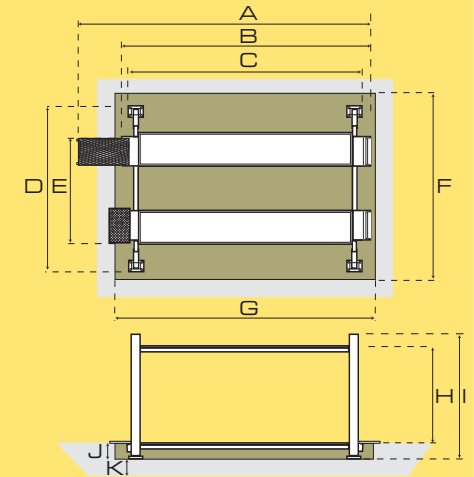

B440 Class 4

B450 Class 7

A 5385	G 4755	A 6285	G 5620
B 4558	H 1960	B 5458	H 1960
C 4387	I 2300	C 5187	I 2300
D 3120	J 165	D 3120	J 165
E 2060	K 200	E 2100	K 200
F 3360		F 3360	

seperate brochure available on vehicle lifts

Boston automated test lanes

An unprecedented and exceptional opportunity for MoT stations

If you save an assistant for just three hours a week to work on repairs or servicing ...
then you can install a complete, approved Boston MoT bay at no real cost whatsoever.



Also illustrated here are suspension tester and slideslip meter. These items are not required for MoT testing, but complete a comprehensive test lane. Details upon request.